

Operations Manual

GMA22-MW/-MS

Controller for wall mounting

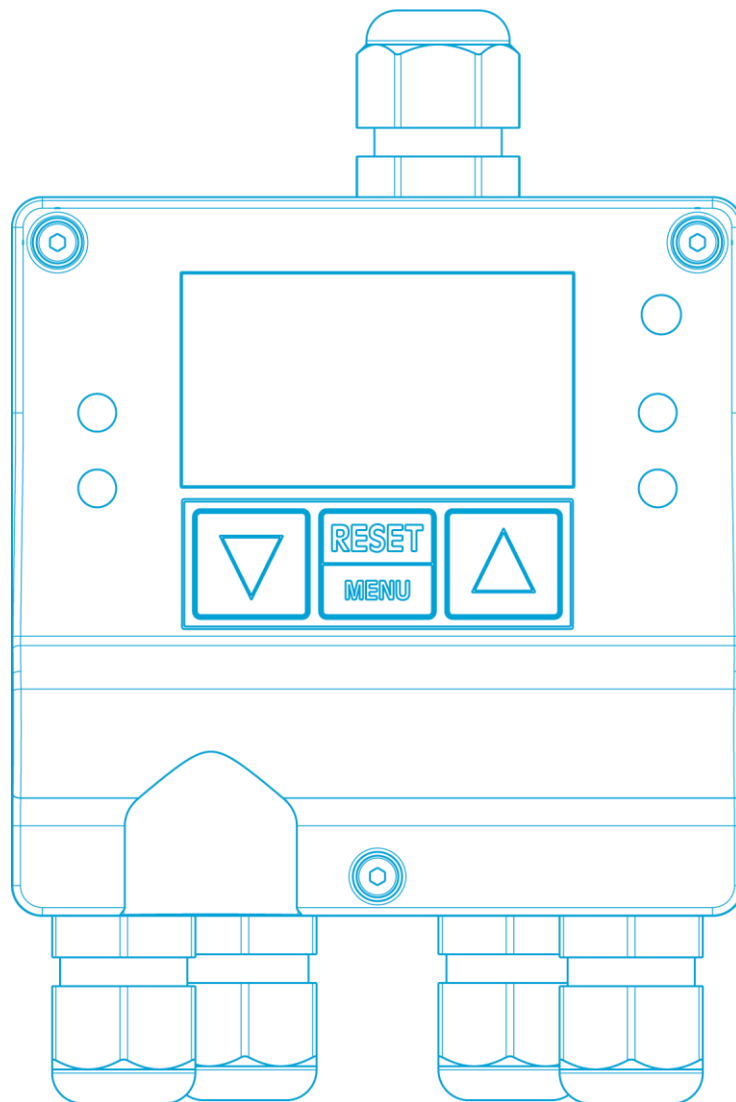

Translation of the original operations manual.

Table of contents

| | Page |
|--|-------------|
| 1 INTRODUCTION | 3 |
| 1.1 For your safety | 3 |
| 1.2 Application and purpose | 3 |
| 1.3 Safety functions | 3 |
| 1.4 Special conditions for safe operation | 5 |
| 2 GAS DETECTION CONTROLLER GMA22-MW/-MS | 6 |
| 2.1 General description | 6 |
| 2.2 Device setup | 6 |
| 2.2.1 Control buttons | 6 |
| 2.2.2 LED status indicators | 6 |
| 2.2.3 LCD graphical display | 7 |
| 2.2.4 Optical and acoustic alarms | 7 |
| 2.2.5 USB socket and microSD slot | 7 |
| 2.3 Analog input | 7 |
| 2.4 Digital RS485 interface | 7 |
| 2.5 Relay | 8 |
| 2.6 Memory card as data logger | 8 |
| 3 ASSEMBLY AND INSTALLATION INSTRUCTIONS | 9 |
| 3.1 Mounting location and housing attachment | 9 |
| 3.2 Electrical connections | 9 |
| 3.2.1 Safety notes | 9 |
| 3.2.2 Power supply and separating device | 10 |
| 3.2.3 Floating relay contacts | 10 |
| 3.2.4 External power supply with 24V DC | 10 |
| 3.2.5 Connection of transmitters with analogue interface | 10 |
| 3.2.6 Connection of transmitters with digital interface (RS485) | 10 |
| 3.2.7 Connection of relay modules with digital interface (RS485) | 10 |
| 3.3 Commissioning | 11 |
| 3.4 Examples of different system variants | 11 |
| 4 OPERATING INSTRUCTIONS | 12 |
| 4.1 Keyboard and operation | 12 |
| 4.2 Measuring mode | 12 |
| 4.2.1 Measuring ranges and tolerance band (deadband) | 12 |
| 4.2.2 Alarms | 13 |
| 4.2.3 Measuring range exceeded | 13 |
| 4.2.4 Data logger function | 14 |
| 4.2.5 Maintenance request | 14 |
| 4.3 Special states | 16 |
| 4.3.1 System start | 16 |
| 4.3.2 Start up (running-in period) | 16 |
| 4.3.3 Malfunction | 16 |
| 4.3.4 Maintenance | 20 |
| 4.3.5 Configuration by parameterization | 20 |
| 4.4 Main menu | 21 |
| 4.4.1 Main menu / "Status GMA | 21 |
| 4.4.2 Main menu / "Status data logger | 21 |
| 4.4.3 Main menu / "Info GMA" | 22 |
| 4.4.4 Main menu / "Info Measuring Points" | 22 |
| 4.4.5 Main menu / "Info Relay" | 22 |
| 4.4.6 Main menu / "Tests | 22 |
| 4.4.7 Main menu / "Service Menu" | 23 |
| 4.5 Service Menu | 23 |
| 4.5.1 Service Menu / "System Settings | 23 |
| 4.5.2 Service Menu / "Data Logger" | 24 |
| 4.5.3 Service menu / "Measuring Points" | 24 |
| 4.5.4 Service Menu / "Relay" | 25 |
| 4.5.5 Exit Service Menu | 26 |
| 5 ANNEX | 27 |
| 5.1 Cleaning and care | 27 |
| 5.2 Service and maintenance | 27 |

| | | |
|-------|--|----|
| 5.2.1 | Visual inspection | 27 |
| 5.2.2 | Functional check | 27 |
| 5.2.3 | System control (Proof Test) | 27 |
| 5.2.4 | Repair | 27 |
| 5.3 | Spare parts and accessories | 28 |
| 5.4 | Notes on the environmentally friendly disposal of used parts | 28 |
| 5.5 | Technical data | 29 |
| 5.6 | EU Declaration of Conformity | 30 |
| 5.7 | Housing drawing and mounting template | 31 |

1 INTRODUCTION

1.1 For your safety

In accordance with the law on the provision of products on the market (Product Safety Act - ProdSG), this operating manual refers to the intended use of the product and serves to protect the safety and health of persons. It must be read and observed by all persons who apply or use, maintain, service and check this product. This product can only fulfil the tasks for which it is intended if it is used, maintained, serviced and checked in accordance with the instructions of GfG Gesellschaft für Gerätebau mbH.

Otherwise, the warranty provided by GfG Gesellschaft für Gerätebau mbH becomes void. Settings in service mode may only be carried out by qualified personnel.

1.2 Application and purpose

The GMA22-MW/-MS is a gas detection controller for wall mounting which, in conjunction with connected transmitters, forms a fixed gas detection system for the continuous measurement of gas concentrations and is used to issue a warning about combustible gases or vapours in the range below the lower explosion limit and about toxic gases in the ambient air, as well as to measure oxygen (deficiency, excess or inertisation). External relay modules GMA200-RT/RTD are additionally available. Section 3.4 "Examples of different system variants" shows some examples for the combination of various system components.

The GMA200Config software program is required to configure the GMA22-M gas detection controller and the GMA200-RT and GMA200-RTD relay modules. The GMA200Config configuration software is not described in these operating instructions. (For reference see OM 222-000.48). Likewise, the GMA200-RT/RTD relay modules are not described in these operating instructions. (For reference see OM 222-000.44).

Function and maintenance of the different transmitters are described in separate operations manuals.

1.3 Safety functions

Two different safety functions can be realized with the GMA22-M and, in combination with the GMA200-R, a third safety function can also be realized. The information flow of the safety functions (SF) is as follows:

- SF1:**
 - Analogue transmitter input of the GMA22-M (4-20mA or 0.2-1mA)
 - Signal processing in the GMA22-M
 - Internal relay outputs of the GMA22-M
- SF2:**
 - Digital RS485 transmitter input of the GMA22-M (RS485 bus)
 - Signal processing in the GMA22-M
 - Internal relay outputs of the GMA22-M
- SF3:**
 - Digital RS485 transmitter input of the GMA22-M (RS485 bus)
 - Signal processing in the GMA22-M
 - Data transmission with RS485 bus
 - Data processing in the GMA200-R
 - Relay outputs of the GMA200-R

If the fault relay drops, the outputs of the safety functions SF1, SF2, SF3 are invalid. Therefore, an evaluation of the switching status of the fault relay is absolutely necessary. It must also be possible to detect short-time faults of approx. 3 seconds.

It is also possible that during maintenance work on transmitters or by locking measuring points or relay outputs, the safety function may be at least partially restricted (inhibit). For this reason, it is also necessary to evaluate the switching status of the maintenance relay.

1.4 Special conditions for safe operation

For safety reasons, only components authorized by the manufacturer GfG may be used.

The following requirements from the metrological standards EN 60079-29-1 (EX) and EN 50104 (OX) must be taken into account:

- Alarms with switch-on delay should not be used for safety-related purposes. If their use is unavoidable, the time delay must be set to the smallest value possible for the required application. The maximum possible rate of increase of the gas concentration must be taken into account when setting the on-delay.
- When measuring combustible gases with transmitters that can provide signals in the measuring range at concentrations above the full scale, the latching function must be activated when the measuring range is exceeded ("Filter time constant" setting 0s)
- When measuring flammable gases, the "Resolution" parameter may be set to a maximum of 1% of the full scale value and the "Tolerance band" parameter may be set to a maximum of 5% of the full scale value.
- When measuring oxygen, the parameter "Error message when underrange" must not be set to a value below -5% of the measuring range end value.
- When measuring oxygen, the "Resolution" parameter may be set to a maximum of 1% of the measuring range end value but not higher than 0.1Vol%. The "Tolerance band" parameter may be set to a maximum of 2% of the measuring range end value.

From the metrological standards EN 45544-1 with EN 45544-2 or with EN 45544-3 (TOX) the following requirements must be considered:

- When used in accordance with EN 45544-2, the GMA22 is suitable for operation with transmitters where the output current at the workplace limit is between 4.48mA and 12mA.
- When used in accordance with EN 45544-2, the "Resolution" parameter may be set to a maximum of 1% of the full scale value of the measuring range and not higher than 5% of the occupational exposure limit.
- The lower range value is a maximum of 0.6% of the measuring range. It becomes smaller if the "Resolution" parameter is set to a smaller value.
- When used according to EN 45544-2, the "Tolerance band" parameter must be set to the lower range value (calculated for the combination of GMA22 and connected transmitter) or to a smaller value.
- When used according to EN 45544-3, the "Resolution" parameter may be set to a maximum of 1% of the full scale value and the "Tolerance band" parameter to a maximum of 5% of the full scale value.

According to the requirements of EN 60079-29-1, EN 45544-1/-2/-3 and EN 50104, the alarms with the highest safety significance must be configured as latching for each measuring point. In addition, relays for safety-relevant switching operations must be configured in such a way that they cannot be reset if an alarm condition is present.

Likewise, at least one internal relay must be configured as a collective message for all measuring point faults (FLT/TRM) and for GMA faults (FLT/GMA).

For measuring points for monitoring toxic gases and vapours according to EN45544-2 (exposure measurement), the following configuration restrictions apply to transmitters with analogue interface:

- A transmitter with analogue 4-20mA interface must be parameterized.
- A linear transmission characteristic must be parameterized.
- The measuring range end value may be a maximum of 33 times the smallest limit value to be monitored, i.e. the alarm threshold may be a minimum of 3% of the measuring range end value.

In accordance with the requirements of EN 50271 section 4.5, in the case of digital data transmission between the transmitter and GMA200, when using the internal relays, the measured value evaluation and alarming is only suitable for transmitter setting times from $t_{90} \geq 10s$.

If the GMA22-M controller is used in the area of application of the Machinery Directive according to EN 62061 or ISO 13849-1, the alarm relays must be parameterized in the closed-circuit current principle. Alternatively, comparable safety requirements must be observed (e.g. by using a redundant or fail-safe power supply).

2 GAS DETECTION CONTROLLER GMA22-MW/-MS

2.1 General description

The design and construction of the GMA22-MW and GMA22-MS controllers offers flexible, simple and clear operation in industrial and commercial applications for measuring combustible and toxic gases/vapours and for measuring oxygen concentrations.

Using the "GMA200Config" software program, measuring points and relays can be configured quickly and easily, even when expanding already installed GMA22-M gas detection systems. For example, measuring point designation, transmitter type, gas type and measuring range as well as 3 individual or pre-set alarm limit values per measuring point can be configured.

2.2 Device setup

Up to 4 transmitters with digital RS485 interfaces can be connected to the GMA22-M, or one transmitter with analogue 4-20mA or with 0.2-1mA interface. A microprocessor evaluates the analogue or digital input signals of the connected transmitters and shows the gas measured values on the display. LEDs signal the status of the controller, the measuring points and the relays. The connection of transmitters with analogue interface is described in section 3.2 "Electrical connections".



2.2.1 Control buttons



In measuring mode, the arrow keys are used to navigate between different screens with different measuring point displays and the RESET key for alarm for alarm acknowledgement. The buttons are also used for menu control, to call up information and in service mode to change some settings. This is described in more detail in section 4 "Operating instructions".

2.2.2 LED status indicators

LED status indicators on the GMA22 controller display the following states during operation depending on the event:

- Green LED → Operating status (ON)
- Yellow LED (continuous) → Fault (FLT) of the GMA or the transmitters
- Yellow LED (flashing) → Service (SRV) or Service Request (SRQ)
- Red LEDs (both) → Alarm 2 (AL2) or Alarm 3 (AL3)
- Red LED (lower) → Alarm 1 (AL1)

If an alarm has been triggered, one or both red alarm LEDs will continue to flash until the alarm condition is no longer met for a non-sustained alarm and that alarm is automatically reset. However, if the alarm condition for any alarm is still fulfilled and is acknowledged by the RESET button, the LED flashes continuously. If an alarm is then also triggered by another measuring point, the corresponding alarm LED starts flashing again.

2.2.3 LCD graphical display

In the measuring mode, the measuring points are shown in the graphic display with numbers, designations and the current measured values. You can switch between the collective and individual displays using the operating keys. In the event of an alarm, the system automatically switches to the alarm display.

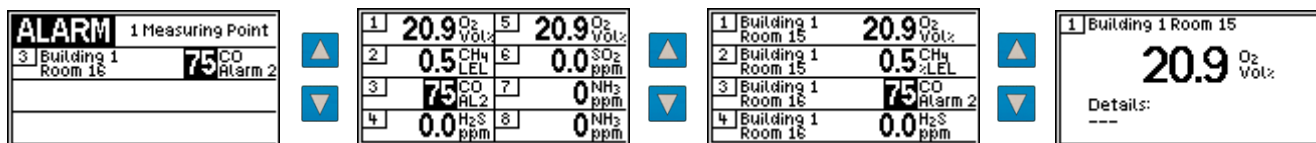

The LCD display has a red/green backlight that can be made brighter by pressing any control button. In the event of an alarm or fault, the red backlight is automatically activated instead of the green one. The display of faults (FLT), maintenance requests (SRQ) and other messages (MSG) is still possible in the main menu under GMA status even after they have been acknowledged with the RESET button.

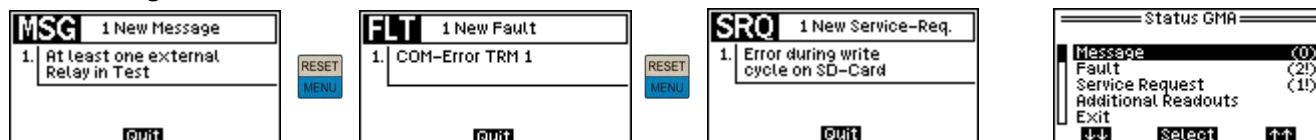

Further details on the displayed information, the operation and the menus are described in paragraph 4 "Operating instructions".

2.2.4 Optical and acoustic alarms

In case of an alarm the two red LEDs in the housing of the GMA22-M start blinking. Additionally, the backlight of the display changes from green to red.

In addition, a horn is integrated into the housing of the GMA22 for acoustic alarm, which is triggered as soon as the assigned alarm configuration for one or more measuring points is exceeded or undercut (for configuration see section 4.2.2.1).

The horn can be assigned to certain alarm functions and measurement points by the GMA200Config software in the same way as an "internal relay".

2.2.5 USB socket and microSD slot

The GMA22 has a USB socket and a slot for a microSD card inside the housing. The USB socket serves only as an interface for configuration purposes. Connected with a USB cable, the GMA22 can be configured for a wide range of measuring tasks from a PC or laptop with the help of the GMA200Config software. The microSD slot is located inside the housing cover and is intended for normal microSD cards up to a capacity of 2GB. This memory card can be used as a data logger if the GMA22 is equipped with the data logger option (see section 2.6 "Memory card as data logger").

2.3 Analog input

A transmitter with analogue 4-20mA or with analogue 0.2-1mA interface in two-wire or three-wire technology can be directly connected to the GMA22-M.

As an alternative, a transmitter with ACDC-capable 4-20mA interface can be connected.

The interface type for which the analogue input is used (analogue 0.2-1mA or analogue 4-20mA or analogue 4-20mA with ACDC) can be set with the GMA200Config software. Hardware-wise the analogue inputs are identical.

2.4 Digital RS485 interface

The GMA22 has a digital RS485 interface. Depending on the current consumption of the transmitters, up to four GfG transmitters with digital RS485 interface and up to four external relay modules GMA200-RT/RTD can be connected to this interface.

2.5 Relay

Internal relays:

The GMA22-MW with power supply unit has 3 internal relays with one floating changeover contact each and one relay with a floating normally open contact. The GMA22-MW without power supply unit has 4 internal relays with one floating changeover contact each.

With the GMA22-MS, both versions (with or without power supply unit) have 4 relays internally, each with a potential-free normally open contact.

To implement defined safety measures and alarms, 2 or 3 relays can be freely configured using the "GMA200Config" software program. A further relay is available for safety-related fault indication and one more for maintenance indication.

If a third alarm relay is required, the fault message and the maintenance message can be combined with one relay. The connections of the internal relay contacts are described in paragraph 3.2 "Electrical connections". If the number of internal relays is not sufficient, they can be extended by external relay modules.

External relay modules:

A relay module GMA200-RT/RTD enables the extension by another 16 freely configurable relays with one floating changeover contact each. A total of 4 relay modules with 64 additional relays can be managed via the GMA22-M controller. The GMA200-R relay modules are connected to the GMA22-M controller via a digital RS485 interface, which also permits spatial separation of the relay modules (max. 1,200m).

Data transmission to external relay modules is typically performed with a cycle time of 1.0 seconds. If the data transmission is disturbed for a short time, the reaction time of the relay module can be extended to <4 seconds. If the data transmission to the relay module is disturbed for a longer period of time, a fault is reported at the GMA22-M from the third successive faulty data transmission.

The relay module is not described in this operating manual (see BA 222-000.24)

Configuration of the relays:

The internal and external relays are configured exclusively via the GMA200Config software, which offers extensive options for assigning the relays to the alarm functions and to individual measurement points or measurement value groups.

Configuration options:

- Open-circuit principle / closed-circuit principle
- Individual alarms per measurement loop and alarm limit value
- Collective or group alarms
- Fault messages
- Configuration of AND/OR links
- Voting functions (e.g. 2 out of 3 measurement loops)

2.6 Memory card as data logger

The GMA22-M can optionally be equipped with a data logger for storing measured values. Inside the housing there is a slot for a microSD card up to a capacity of 2GB. This microSD card must be formatted with FAT(FAT16). Further details on the operation of the data logger are described in section 4.2.4 "Data logger function".

3 Assembly and installation instructions

3.1 Mounting location and housing attachment

The GMA22 is intended for indoor wall mounting and must not be installed in explosion hazard areas. Care must be taken to ensure that the device is exposed to as little vibration as possible. When determining the installation location, care must be taken to ensure that the GMA22 is always freely accessible for service and maintenance.

To mount the unit, the three Allen screws have to be loosened and the housing cover removed. The housing is fixed with three pan-head or cylinder head screws with a diameter of 3.5-4.5mm. The screw heads should have a diameter of 7-9mm with a flat bearing surface (use washers if necessary). The lower screw has to be screwed into the wall so far that a gap of 4mm is left for latching the housing. The two upper screws must be tightened with a torque of approx. 1Nm above the screw-in torque.

3.2 Electrical connections

The power supply, transmitter and relay contacts are connected according to the connection diagrams, which are also inside the device. In the following the terminal assignments of the GMA22-MW and GMA22-MS are shown with and without internal power supply.

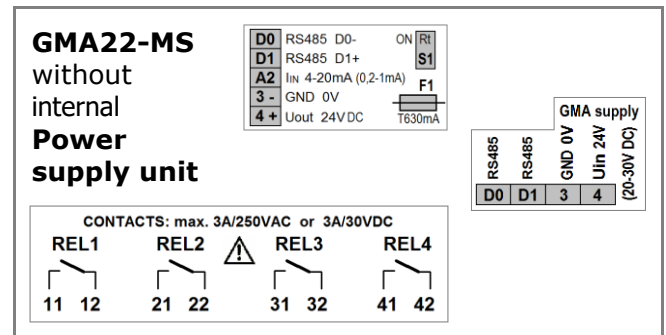
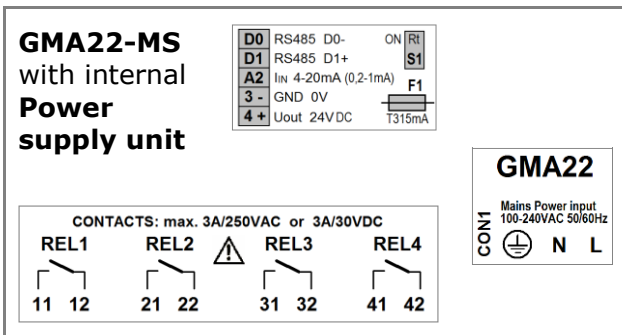
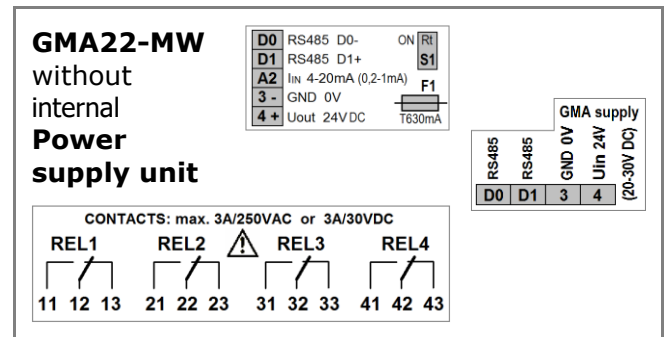
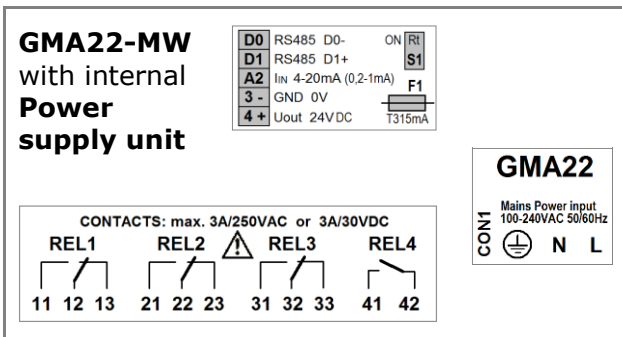

When the housing cover is opened, various points inside the GMA22 are marked with symbols. These symbols have the following meaning:



Electric shock hazard



Protective earth connection



General Warnings see operations manual

3.2.1 Safety notes



The electrical installation must always be carried out in accordance with DIN VDE 0100 or a comparable country-specific standard. Cables with voltages dangerous to touch e.g. 230VAC and cables with non-hazardous voltages e.g. 24VDC must be laid separately. The cables used must be suitable for the connected transmitters or devices. If the GMA22 is also operated at ambient temperatures of +40...55°C, temperatures of +60...70°C may occur in the area of the upper terminals, depending on the load on the power supply unit from the transmitters. When selecting the cable type, its thermal resistance must be taken into account. After connecting the cables, all cable entries must be closed tightly and tightened firmly. If, due to maintenance work, the housing cover of the GMA22 has to be opened during operation, it must be ensured that potentially dangerous voltages are present in the area of the mains connection terminals at CON1 and in the area of the relay connection terminals X11-42(43). It is essential to avoid touching these areas.

3.2.2 Power supply and separating device



If the GMA22 is supplied with mains voltage (100...240VAC) via the CON1 terminals [L,N], an "isolating device" must be provided in the supply line. This isolating device must comply with the requirements of IEC60947-1 and IEC60947-3, be clearly identified as a GMA22 isolating device and be accessible. The mains supply line must have a conductor cross-section of at least 0.75mm² and be protected with an appropriate overcurrent protection device. The protective conductor must have at least the same cross-section as the L and N conductor and is connected to the terminal marked with the protective conductor symbol.

3.2.3 Floating relay contacts



Additional external warning devices such as indicator lamps, acoustic signalling devices or similar can be connected to terminals X11-42(43) (contacts of relays 1-4). With the GMA22-MW, the contacts of the adjacent relays may only be operated with the same voltage category. Touch dangerous voltages (e.g. 230V AC) and protective extra-low voltages (e.g. 24V DC) must not be connected together to adjacent relays. With the GMA22-MS this restriction does not exist. Here, terminals 13, 23 and 33 are not wired internally.

3.2.4 External power supply with 24V DC

The GMA22 variants without internal power supply can be operated with an external 24VDC supply. This external 24V supply is connected to terminals [3] (GND 0V) and [4] (U_{in}24V) via the middle 4-way terminal block. If an external power supply is used, it should comply with EN60950-1 or have reinforced or double insulation between the mains circuit and the output voltage circuit, as is the case with class II (protective insulation) equipment. If the GMA22 is operated on a 24VDC supply, the voltage must be safety extra-low voltage (SELV) or protective extra-low voltage (PELV). Otherwise, the same requirements apply to the insulation of this 24VDC supply as to the power supply units described above. The supply line to the GMA should have a wire cross-section of at least 0.75mm². It must be protected with an overcurrent protection device which meets the requirements of DIN EN 60127, has a rated current of 1...2A and slow cut-off behaviour. For mounting on a DIN rail (top-hat rail), a fuse terminal block of the PT4-HESI, UT4-HESI or ST4-HESI series from Phoenix Contact or the 281-611 series from WAGO with corresponding end plates could be used.

3.2.5 Connection of transmitters with analogue interface

A transmitter in three-wire technology with an analogue 4-20mA or 0.2-1mA interface can be connected to the upper 5-gang terminal block at the connection terminals [A2|3-|4+] (I_{IN}|GND|U_{out}24V).

For transmitters with two-wire technology, only the two terminals [A2|4+] (I_{IN}|U_{out}24V) are required. The wire cross-section depends on the current consumption of the transmitter and the length of the cable. For detailed information please refer to the operating instructions of the connected transmitters.

Important note: If 24VDC is accidentally connected to the [A2] (I_{IN}) terminal, the GMA analogue input may be damaged or destroyed.

3.2.6 Connection of transmitters with digital interface (RS485)

Transmitters with a digital interface can be connected to terminals [D0|D1|3-|4+] (RS485|GND|U_{out}24V). However, the total current consumption of all connected transmitters must not exceed 0.3A. Please refer to the operating manuals of the connected transmitters for detailed information. The one to be used

The wire cross-section to be used depends on the current consumption of the transmitters and the cable length.

The picture on the right shows the slide switch S1, which is used to switch on the 120 Ohm terminating resistor R_t at the bus connection when the GMA is connected at the end of the line. (Factory setting: S1=ON)



3.2.7 Connection of relay modules with digital interface (RS485)

An extension of the GMA22-M with one or more external relay modules requires that the connected transmitters also have a digital RS485 interface. External relay modules must then be connected to the same RS485 bus as the transmitters. Depending on the current consumption of the transmitters connected to the bus, an external relay module could possibly be supplied by the power supply unit of the GMA22. However, if the current consumption of the transmitters is already relatively high, the external relay module must be supplied separately with 24VDC.

3.3 Commissioning

After completion of the installation of the GMA22 and the transmitters and, if necessary, the relay modules and after the power supply has been ensured, commissioning can be carried out.

According to national regulations, gas detection devices must be tested for function by a competent person after installation but before starting measuring operation (initial start-up). In Germany, "DGUV Information 213-056 (Leaflet T 021 / previously BGI 836 Section 8.1)" and "DGUV Information 213-057 (Leaflet T 023 / previously BGI 518 Section 8.1)" apply.

3.4 Examples of different system variants

The following three examples show the different connection possibilities of transmitters on the GMA22. Individual transmitters, as shown on the left of the picture, can be connected to the GMA22 either with an analogue interface (e.g. 4-20mA) or with a digital interface (RS485 bus).

If several transmitters are to be connected to the GMA22 at the same time, then these transmitters must be connected via the RS485 bus as shown in the figure in the middle and right. The picture on the right shows that in addition to the transmitters, external relay modules (GMA200-RT/-RTD) can also be connected to the RS485 bus.

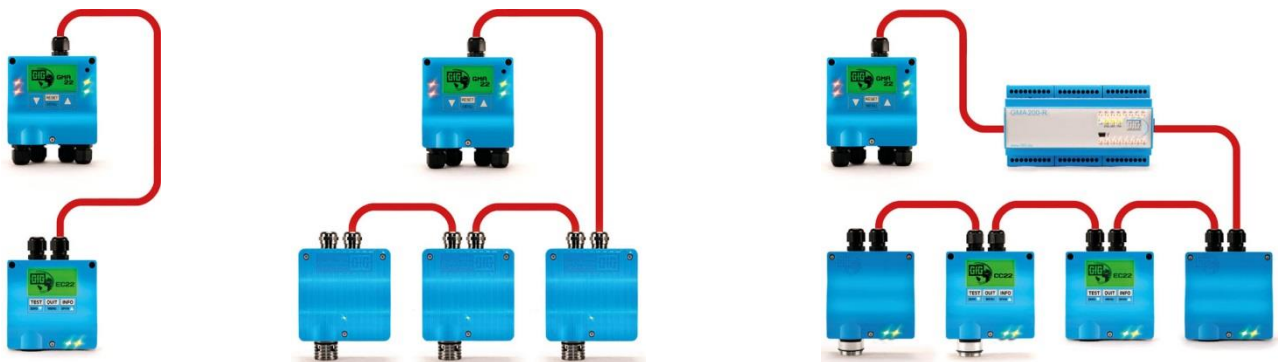

Depending on how many transmitters and relay modules are to be connected to the GMA22 via the RS485 bus, their power supply may have to be provided by additional external components.

4 Operating instructions

4.1 Keyboard and operation

The keyboard of the GMA22 can be used to acknowledge alarms and messages on the display. In the main menu and in the service menu you can navigate with the keyboard. It can even be used to change some configuration settings in the service menu. The functions of the individual keys and how to navigate through the menus are described below:

Butto Function on actuation:

n



Alarm acknowledgement for latched alarms (with short keystroke)
Activation of main menu (with keystroke >3s)



Change to menu items in the main menu, with single measuring point display to single display of other measuring points, change in the total display (1-8), digit selection for entering the password in the service menu.



Function on actuation: Change to menu items in the main menu, with single measuring point display to single view of other measuring points, digit selection for entering the password in the service menu.

If the GMA22-M is in measuring mode, access to the menus is by pressing and holding the  key. The main menu is then displayed first. From there you can also switch to the "Service menu".

4.2 Measuring mode

The normal measuring mode of the GMA22-M gas detection controller is reached approx. 30 seconds after switching on the power supply. A short optical signal indicates readiness to measure. Depending on the transmitter type and its running-in period, the display shows "SRT" assigned to the respective measuring point during the running-in period. Typically, the run-in time is between 1 and 2 minutes, depending on the transmitter.

In the normal measuring mode, all LEDs are inactive and the power indicator ON lights up green. The display shows all configured measuring points (up to max. 4 measuring points, see section 2.2.3 "LCD graphical display", for changes to the display see section 4.1).

4.2.1 Measuring ranges and tolerance band (deadband)

The measuring ranges can be displayed in the main menu of the GMA22-M under "Info measuring points" (see section 4.4.4). For a better overview, the details of the configured measuring ranges with range starts, tolerance bands and resolutions are documented on the "Measuring point overview" page of the supplied GMA22 configuration.

With older purely analogue gas measuring transmitters (such as the CS21, CI21, EC24), the tolerance band suppresses small fluctuations in the zero point range of the GMA22 for toxic and flammable gases. When measuring oxygen, small fluctuations of 20.9 vol% O₂ (fresh air range) may be suppressed. To avoid jumps, the display value is adjusted to the actual measured value up to twice the value of the tolerance band. This tolerance band is always activated, but can also be switched off for individual measuring points using the GMA200Config software.

In the case of processor-controlled gas measuring transmitters with analogue or digital output signal (e.g. CS22, EC22, CC28), such small fluctuations in measured values are already suppressed in the transmitter. The tolerance band can be deactivated here directly at the transmitter. The operating manuals of these gas transmitters describe the measuring range, tolerance band and resolution in more detail.

4.2.2 Alarms

Three alarm thresholds within the measuring range can be configured for each measuring point. When alarm thresholds are exceeded or not reached, the red alarm LEDs (collective alarm display) and the integrated acoustic alarm are activated. Detailed information on the gas concentration level, alarm status (AL1, AL2 or AL3) of the respective measuring point are shown simultaneously on the graphic display (see section 2.2.3 "LCD graphical display").

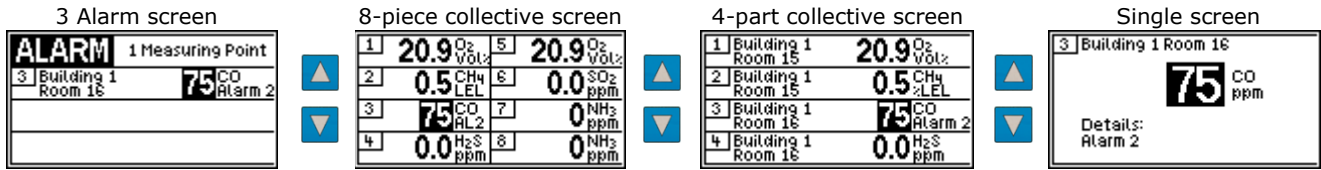

In addition, depending on the configuration, the configured relays R1-R3 are activated (typical configuration).

4.2.2.1 Alarm configurations

The GMA200Config software can be used to configure the following settings for each measuring point:

- Alarm threshold Alarm 1 (change also possible in the Main menu / Service menu)
- Alarm threshold Alarm 2 (change also possible in the Main menu / Service menu)
- Alarm threshold Alarm 3 (change also possible in the Main menu / Service menu)
- Alarm overrange, latching
- Alarm overrange, non-latching
- Alarm underrange, latching
- Alarm underrange, non-latching
- Alarm with switch-on delay (up to max. 3 minutes)
- Alarm with switch-off delay (up to max. 60 minutes)

4.2.2.2 Alarm acknowledgement (RESET)

The behaviour of the alarm LEDs before and after alarm acknowledgement is described in section 2.2.2 "LED status indicators".

Non-sustained alarm:

A non-latching alarm will automatically reset at gas concentrations below (above) the alarm threshold and the associated relay(s) will be disabled.

Self-locking alarm:

A latching alarm remains in effect even if the gas concentration is below (above) the alarm thresholds. The alarm and the assigned relay(s) can only be acknowledged with the RESET button on the GMA22 after the alarm threshold has been undercut (exceeded).

Acknowledgeable alarm relay:

Relays can be configured to be acknowledgeable and are reserved exclusively for connection with acoustic/optical messages. Acknowledgement is done by pressing the RESET button on the GMA22.

4.2.3 Measuring range exceeded

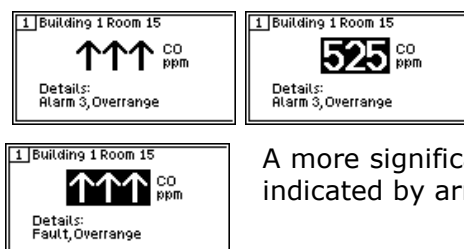

An exceeding of the measuring range between 105% or 100% and 112.5% of the measuring range is indicated by upward pointing arrows alternating with the display of the measured value.

A more significant exceeding of more than 112.5% of the measuring range is indicated by arrows pointing permanently upwards.

If flammable gases and vapours are measured at the measuring point with a transmitter with a heattint sensor, then if the measuring range is exceeded significantly and because of the ambiguity of the measuring signal, the exceeding of the measuring range is stored in a self-retaining manner. To prevent damage to the heat tone sensor at high gas concentrations, the sensor is de-energized in some transmitter types. Nevertheless, a signal is still generated by the separating grid that corresponds to a measured value of 112.5% LEL. This state is maintained until it is consciously acknowledged.

Only when it has been ensured that no flammable gas or at least no high gas concentration is present at the transmitter may this condition be acknowledged at the transmitter.

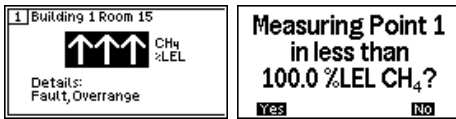

If the transmitter has a digital RS485 interface or ACDC-capable 4-20mA interface, this state can also be acknowledged in the individual gas display of the GMA22 by pressing the **RESET** button and then **Yes**.

4.2.4 Data logger function

If the GMA22 is equipped with the optional data logger, the measured values from all measuring points can be stored on a FAT(FAT16)-formatted microSD card.

The measured values are always saved in an average value file with a configured recording interval and a configured file re-set. In this file, the minimum and maximum values for each measuring point are stored for each interval in addition to the average values, so that no essential information is lost even with longer recording intervals. (Factory setting = 5 minutes)

As soon as an alarm is triggered, the instantaneous values of all measuring points are also stored in an additional alarm file, usually at a shorter recording interval. (Factory setting = 10 seconds)

The data logger is configured with the GMA200Config software. This allows the recording intervals for both file types to be set as follows:

- Average file: 5/10/15/20/30 seconds or 1/2/3/5/10/15/20/30/60 minutes
- Alarm file: 5/10/15/20/30/60 seconds

Depending on the configuration, the measured values are saved under a calendar file name. The times for the file creation can be configured as follows:

- daily (file name: year-month/day/type*) e.g. 13-0622M.txt
- weekly (file name: year-W/KW/type*) e.g. 13-W24M.txt
- monthly (file name: year-month/type*) e.g.13-06M.txt
- yearly (file name: year-00/type*) e.g. 13-00M.txt

*M=mean value / A=torque values at alarm

To read the data, the SD card must be removed.



Before removing the SD card, the data recording must be temporarily stopped as follows (pause function)

- Activate the main menu of the GMA22 by pressing and holding the key
- Select with "▼" Status Data Logger" and press to select
- Select "Stop REC" by pressing the button.

In this menu item, the status (memory capacity still available) is also displayed.



If the SD card is inserted into the slot again after reading, data recording can be restarted in the same menu item by pressing "Start REC". If this is not done manually, an automatic recording start is initiated 15 minutes after the recording stop.

However, if the SD card is not inserted again within these 15 minutes and the data logger is configured to trigger a maintenance request in case of a missing or faulty SD card, then the data recording should be switched off correctly in the service menu. This is described in section 4.5.2 "Service Menu / "Data Logger

4.2.5 Maintenance request

During normal measurement operation, a maintenance request (SRQ) can be triggered. In this case, the yellow LED "SRV/SRQ" flashes and a corresponding message appears on the display. Optionally, relays can be parameterized to switch in case of a maintenance request. The maintenance request has no influence on the normal measuring operation. The SRQ message in the display can be acknowledged by pressing the "RESET" button. Via the "Main menu" the message can still be called up under "Status GMA" / "Maintenance required". There are the following options that can trigger a maintenance request:

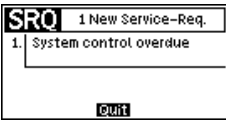
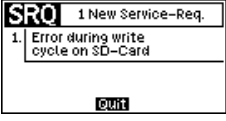
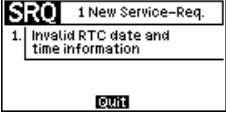
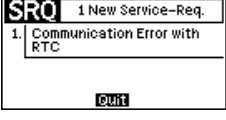
Maintenance request of the GMA22

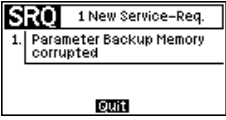
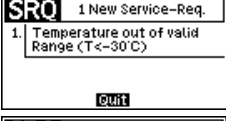
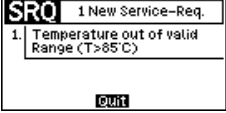
| Service Request | Cause and remedy |
|--|--|
|  | <p>Here, the deadline for the next system check was exceeded, which usually has to be carried out once a year.</p> <p>Remedy: The system check should be performed as soon as possible. The date for the system check can only be changed with the GMA200Config software.</p> |
|  | <p>An error has occurred while writing to the SD card, so that the data logger no longer records any data. The cause may be a defect in the SD card itself or in its contacts. It is also possible that the SD card was removed without (permanently) stopping the data recording.</p> <p>Remedy: Remove the card and read out and save the data on the PC. Then format the SD card with FAT and reinsert it or replace it completely if necessary.</p> |
|  | <p>Date and time are invalid in the clock module of the GMA22. This indicates that the buffer battery of the clock module is empty or not properly contacted, so that when the GMA22 is switched off, the clock module cannot continue to work and thus date and time are lost.</p> <p>Remedy: Set the date and time in the service menu. In case of recurrence, call GfG service (exchange GMA22). The battery cannot be changed.</p> |
|  | <p>Date and time cannot be read by the clock module. This indicates a hardware defect on the mainboard of the GMA22. However, measured value acquisition and evaluation runs independently of this time information.</p> <p>Remedy: Set the date and time in the service menu. In case of recurrence, call GfG service (exchange GMA22).</p> |
|  | <p>The GMA22 can no longer communicate with the processor external EEPROM. This means that the data stored in the second parameter memory (e.g. designation texts) cannot be accessed. Therefore, there is no backup copy of the parameters in the working memory.</p> <p>Remedy: If this maintenance request is still displayed as current in the main menu, then the GfG service should be used (replace GMA22).</p> |
|  | <p>The parameters stored in the backup copy are faulty. Copying the parameters from the main memory to the backup copy did not eliminate this error either.</p> <p>Remedy: If this maintenance request is still displayed as current in the main menu, then the GfG service should be used (replace GMA22).</p> |
|   | <p>Temperature on the mainboard of the GMA is outside the permissible range ($T < -30^{\circ}\text{C}$) or ($T > 85^{\circ}\text{C}$). If the temperature does not really have this value, it indicates a hardware defect on the GMA mainboard. If the temperature falls below -30°C, the measured values in the display are also updated much more slowly.</p> <p>Remedy: Normalize temperature influence or, if necessary, call GfG service (replace GMA).</p> |

Maintenance request from the transmitter

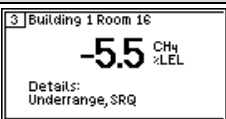
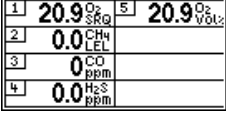
| Service Request | Cause and remedy |
|---|---|
|  | <p>At the transmitter the signal zero point has drifted away negatively, so that the measuring range of the transmitter was clearly fallen below (Underrange typ. $< -5\%$ of measuring range).</p> <p>Remedy: The zero point should be adjusted at the transmitter.</p> |
|  | <p>Maintenance request for a transmitter with digital RS485 interface. In this example, the sensor must be replaced because it will soon be used up. A corresponding message or signal is given at the transmitter.</p> <p>Remedy: Call GfG service (replace sensor if necessary).</p> |

4.3 Special states

The device can be in various special states.

4.3.1 System start



During system start up the GfG logo, the device name and first the version number of the bootloader and then the version number of the mainboard firmware is displayed.



During this time various internal self-tests are carried out. After completion of the internal tests, a short test of the display, all LEDs and the horn is performed.

During the whole time the yellow fault LED is on and the relays are off.

If no errors have occurred during the internal self-tests, the instrument then switches to the special state start up (running-in period) or to normal measuring operation.

4.3.2 Start up (running-in period)

The connected transmitters usually require a run-in period. In order to enable digital transmitters to start up themselves, the GMA22 waits 30 seconds after switching on until it addresses the transmitters with digital RS485 interface.

| | | | | | |
|---|-----|------------------|---|-----|-----------------|
| 1 | --- | O ₂ | 5 | --- | O ₂ |
| | --- | SRT | | --- | SRT |
| 2 | --- | CH ₄ | 6 | --- | SO ₂ |
| | --- | SRT | | --- | SRT |
| 3 | --- | CO | 7 | --- | NH ₃ |
| | --- | SRT | | --- | SRT |
| 4 | --- | H ₂ S | 8 | --- | NH ₃ |
| | --- | SRT | | --- | SRT |

Even if only one transmitter with an analogue interface is connected, at least 30 seconds are waited. Depending on the connected transmitter, the running-in period can vary in length and last from a few seconds to a few minutes. During this time the display shows "SRT" or "**Fault, Start-Up**" for the individual measuring points.

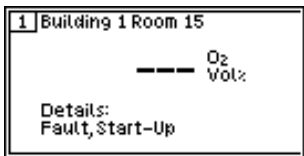

Depending on the transmitter and sensor type, they can switch to normal measuring operation at different times. The relays behave according to the configured functionality, and the fault relay has dropped out. The yellow fault LED "FLT/TRM" is on and only goes out when all measuring points are ready for operation.

4.3.3 Malfunction

With fault messages, a distinction is made between faults in the transmitter measuring point and faults in the GMA controller. In the event of a fault, the yellow LED lights up statically, the corresponding fault relay has dropped out. Fault messages are not self-retaining.





The following fault messages apply to transmitters with **analogue** interface (mA):

| Fault (FLT/TRM) | Cause and remedy |
|-----------------|--|
| | <p>Here the level of the analogue transmitter signal exceeds the current measuring range of the GMA22-M (IIN>24mA or IIN>1.2mA). The cause may be a too high gas concentration at the transmitter or a defect at the transmitter or in the wiring.</p> <p>Remedy: If it is ensured that the gas concentration is not high, the output signal must be checked directly at the transmitter. Replace the transmitter if necessary. Otherwise the transmitter wiring must be checked and repaired if necessary.</p> |
| | <p>Here the measuring range of the transmitter was exceeded to such an extent that the interference level was reached. The level of this interference level is transmitter-dependent (e.g. 22...24mA or 1.1...1.2mA).</p> <p>Remedy: Gas concentration at the measuring point must be reduced again.</p> |
| | <p>Here the measuring range of the transmitter was undercut so far that the interference level was reached. The level of this interference level is transmitter-dependent (e.g. 2.8mA or 0.14mA).</p> <p>Remedy: If it can be excluded that there is no gas at the measuring point, which has a negative cross-sensitivity at the sensor, then the zero point should be adjusted at the transmitter.</p> |
| | <p>Here the level of the analog transmitter signal falls below the current measuring range of the GMA22-M (IIN=0mA). The cause can be a missing power supply at the transmitter, a defect of the transmitter or a line interruption.</p> <p>Remedy: If it is ensured that the power supply of the transmitter is OK, the output signal must be checked directly at the transmitter. Replace the transmitter if necessary. Otherwise the transmitter wiring must be checked and repaired if necessary.</p> |

| | |
|---|---|
|  | <p>Here a short circuit is detected in the transmitter cable or at the transmitter-side cable end. The analog current signal does not behave as if it came from a current source.</p> <p>Remedy: Check the current signal at the GMA22 input and at the transmitter output with a current meter. If necessary, check the cable routing from the transmitter to the GMA22 and repair.</p> |
|---|---|

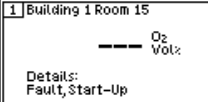
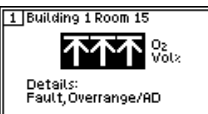
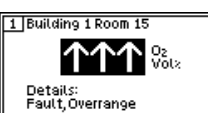



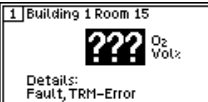
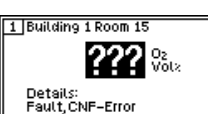





Note: The corresponding instructions in the operating manuals of the connected transmitters must also be observed.

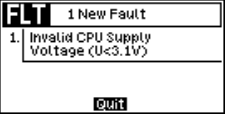
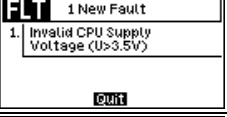
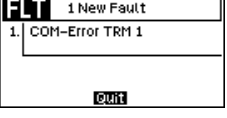
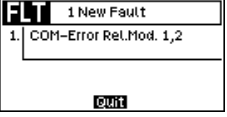

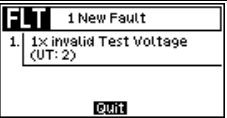



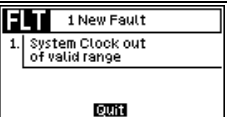
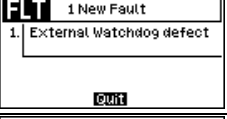

The following fault messages apply to transmitters with **digital** interface (**bus**):

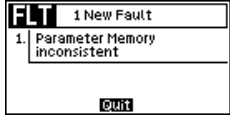
| Fault (FLT/TRM) | Cause and remedy |
|---|--|
|  | <p>Here the transmitter is in the start-up phase. During this time the sensor runs in or is warmed up. This running-in period depends on the transmitter and sensor and can last several minutes.</p> <p>Remedy: The time simply has to be waited for.</p> |
|  | <p>Here the sensor signal in the transmitter has exceeded the measuring range of the transmitter electronics. The cause could be a too high gas concentration at the transmitter or a gas with a very high cross-sensitivity. Possibly the gas sensor or the transmitter electronics are also defective.</p> <p>Remedy: If it is ensured that it is not a high gas concentration or a cross gas, the transmitter must be checked. See the operating manual of the transmitter.</p> |
|  | <p>Here the sensor signal in the transmitter has clearly exceeded the transmitter measuring range (usually >112%). The cause could be a too high gas concentration at the transmitter or a gas with a very high cross-sensitivity. Possibly the gas sensor or the transmitter electronics are also defective.</p> <p>Remedy: If it is ensured that it is not a high gas concentration or a cross gas, the transmitter must be checked. See the operating manual of the transmitter.</p> |
|  | <p>In this case, the sensor signal in the transmitter has fallen significantly below the transmitter measuring range (usually <-7.5%). Possibly there is a gas with a negative cross-sensitivity at the measuring point or the zero point signal has drifted away due to aging of the sensor or environmental influences.</p> <p>Remedy: See operating manual of the transmitter.</p> |
|  | <p>Here the sensor signal in the transmitter has even fallen below the measuring range of the transmitter electronics. Possibly there is a gas with a negative cross-sensitivity at the measuring point or the zero point signal has drifted away due to aging of the sensor or environmental influences.</p> <p>Remedy: See operating manual of the transmitter.</p> |
|  | <p>Here there is a communication disturbance between the GMA and a digital transmitter. The cause could be a missing power supply of the transmitter, a wrong bus assignment, a wrongly set bus address or baud rate at the GMA22-M or at the transmitter. There could also be a hardware interruption of the communication line or the lines could have been connected incorrectly. However, a defect in the transmitter could also have led to the fault.</p> <p>Remedy: Check the power supply of the transmitter, the correct bus assignment, the settings of the bus addresses and baud rates and correct them if necessary. Check bus cabling and correct if necessary.</p> |
|  | <p>Here there is a disturbance of the digital transmitter. Possibly the supply voltage of the transmitter is too low or too high or there is a defect in the transmitter itself.</p> <p>Remedy: Check the power supply of the transmitter and, if necessary, check the transmitter itself. See the operating manual of the corresponding transmitter.</p> |
|  | <p>Here the configuration in the GMA does not match the configuration of the connected transmitter. There may be differences in gas type, gas unit, measuring range or number of decimal places. However, it is possible that only the assignment of the transmitter is incorrect due to an incorrectly set bus address.</p> <p>Remedy: Check correct transmitter assignment and bus address. Check the correct measuring range setting on the transmitter and change if necessary. Otherwise, adjust the configuration of the measuring point in the GMA.</p> |

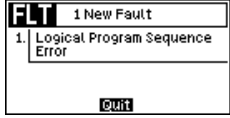
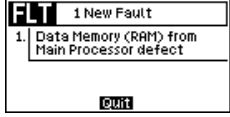
Note: The corresponding instructions in the operating manuals of the connected transmitters must also be observed.

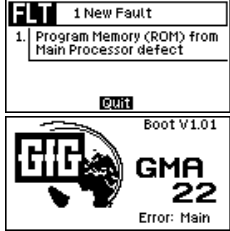
The following fault messages apply to the GMA itself:

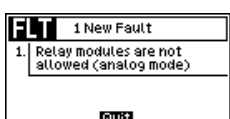
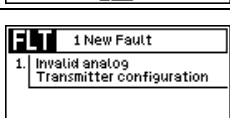
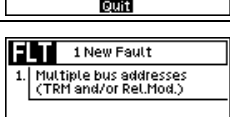
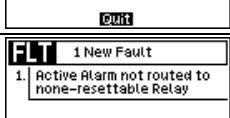

| Fault (FLT/GMA) | Cause and remedy |
|--|---|
|   | <p>If the GMA is only supplied from the PC via the USB cable for configuration purposes and a display is connected, the message "Invalid GMA supply voltage (U< 20V)" would always be displayed. That would be normal.</p> <p>Otherwise the supply voltage of the GMA22 is too low (U< 20V) or too high (U>30V). The cause could be a defective power supply unit.</p> <p>Remedy: For normal operation, check power supply and replace power supply unit if necessary.</p> |
|   | <p>The voltage supply of the internal electronics is too low (U<3.1V) or too high (U>3.5V). This indicates a defect of the GMA22.</p> <p>Remedy: Use the GfG service.</p> |
|  | <p>Communication fault between the GMA22-M and a transmitter on the RS485 bus. The cause could be a missing power supply of the transmitter, a wrong bus assignment, a wrongly set bus address or baud rate at the GMA22-M or at the transmitter. There could also be a hardware interruption of the communication line or the lines could have been connected incorrectly. However, a defect in the transmitter could also have led to the fault.</p> <p>Remedy: Check the power supply of the transmitter, the correct bus assignment, the settings of the bus addresses and baud rates and correct them if necessary. Check bus cabling and correct if necessary.</p> |
|  | <p>Communication fault between the GMA22-M and external relay modules GMA200-R. This could be caused by a missing power supply to the relay modules, incorrectly set baud rates or bus addresses on the GMA22-M or the GMA200-R. For example, the relay modules could simply have been swapped here. There could also be a hardware-related interruption of the communication line or the lines could have been connected in reverse.</p> <p>Remedy: Check the power supply of the relay modules, correct device assignment, the setting of the bus addresses and baud rates and adjust them correctly if necessary. Check bus cabling and correct if necessary.</p> |
|  | <p>The device-internal communication between mainboard and display board is disturbed. The most likely cause is a defect in the ribbon cable connecting both circuit boards. A defect on one of the two circuit boards is also possible.</p> <p>Remedy: Call GfG service and replace ribbon cable if necessary.</p> |
|  | <p>Measured control voltage for testing the processor-internal ADC multiplexers outside the permissible range. The reason for this can be a contact problem on the mainboard or a defective ADC multiplexer.</p> <p>Remedy: If the error occurs repeatedly after a restart, the GMA22 must be replaced.</p> |
|  | <p>The switching function may no longer be possible at the corresponding internal relays. The reason for this can be a defect in the relay, a contact problem on the mainboard or a defect in the monitoring circuit.</p> <p>Remedy: If the error occurs repeatedly after a restart, the GMA22 must be replaced.</p> |
|  | <p>The switching function may no longer be possible on the relays of the external relay module GMA200-RT/RTD. The reason for this can be a defect in the relay, a contact problem on the relay board or a defect in the monitoring circuit.</p> <p>Remedy: If the error occurs repeatedly after restarting the external relay module, the relay module must be replaced.</p> |
|  | <p>An external relay module GMA200-RT/RTD signals a fault. There can be very different reasons for this (e.g. wrong supply voltages, defective program memory, defective data memory, defective parameter memory, etc.)</p> <p>Remedy: If the external relay module has a display, the contents of the display can be read for error limitation. If there is no display here, first check its supply voltage and then, if necessary, establish a connection to the GMA200Config software via the USB port. If the cause cannot be found and eliminated, the external relay module must be replaced.</p> |
|  | <p>The system clock of the GMA22 is too fast or too slow or the reference clock is disturbed. The cause is a hardware defect on the mainboard. Possibly, this also means that communication via the RS485 buses and the USB interface is disturbed.</p> <p>Remedy: The GMA22 must be replaced.</p> |
|  | <p>A malfunction was detected when checking the external monitoring module on the mainboard.</p> <p>Remedy: If the error still occurs after restarting the GMA22, the GMA22 must be replaced.</p> |
|  | <p>The parameters in the main memory contain incorrect data that cannot be corrected automatically due to a hardware defect on the mainboard.</p> <p>Remedy: If the error still occurs after restarting the GMA22, the GMA22 must be replaced.</p> |

| | |
|---|--|
|  | <p>The parameters in the main memory and in the backup copy are each error-free, but have different contents. This may have been caused by a power failure during a configuration change.</p> <p>Remedy: The parameters are saved from the working memory to the backup copy by simply acknowledging this message. The then valid configuration can be checked and, if necessary, corrected with the GMA200Config software.</p> |
|  | <p>The malfunction was triggered because the deadline for the system check was exceeded by at least 30 days. The fact that a fault has been triggered for this reason has been optionally configured.</p> <p>Remedy: Perform a system check and set a new date for the system check.</p> |
|  | <p>The normal program flow is disturbed, so that the correct function of the GMA22 is no longer guaranteed. Possibly there is a defect on the mainboard or the display board.</p> <p>Remedy: The GMA22 automatically carries out a restart three seconds after this error occurs. If this error is reported again, the GMA22 must be replaced.</p> |
|  | <p>The main memory of the main processor on the mainboard is defective.</p> <p>Remedy: The GMA22 automatically carries out a restart three seconds after this error occurs. If this error is reported again, the GMA22 must be replaced.</p> |
|  | <p>Memory of the slave processor on the display board is defective.</p> <p>Remedy: If the error occurs repeatedly after a restart, the GMA22 must be replaced.</p> |
|  | <p>The program in the program memory of the main processor on the mainboard is faulty.</p> <p>Remedy: The GMA22 automatically carries out a restart three seconds after this error occurs. If the check of the program memory by the bootloader shows an error again, then a GfG service technician must carry out a firmware update. If the error cannot be eliminated by the update, the GMA22 must be replaced.</p> |
|  | <p>The program in the program memory of the slave processor on the display board is faulty.</p> <p>Remedy: If the error still occurs after a restart and cannot be eliminated by a firmware update from a GfG service technician, the GMA22 must be replaced.</p> |
|  | <p>After a restart, the slave processor on the display board only runs in the bootloader because the program of the slave processor is faulty.</p> <p>Remedy: If the error still occurs after restarting the GMA22, a firmware update of the processor on the display board must be carried out with the GMA200Config software.</p> |
|  | <p>The bootloader of the main processor on the mainboard does not work properly or was not installed properly due to a memory defect.</p> <p>Remedy: If the error still occurs after restarting the GMA, the GMA must be replaced.</p> |
|  | <p>The bootloader of the slave processor on the display board does not work properly or was not installed properly due to a memory defect.</p> <p>Remedy: If the error still occurs after restarting the GMA, the GMA must be replaced.</p> |
|  | <p>The configuration or activation of external relay modules is not permitted, because the GMA22 is configured for the connection of an analogue transmitter and then relay modules must not be connected or configured at the same time.</p> <p>Remedy: Check and correct the configuration for the external relay modules with the GMA200Config software. If necessary use the GfG service.</p> |
|  | <p>The configuration of several transmitters with analogue interface is not permitted, as the GMA22 only has one analogue interface.</p> <p>Remedy: Check and correct the configuration for measuring points with analog interface using the GMA200Config software. If necessary use the GfG service.</p> |
|  | <p>The configuration for transmitters with digital interface and/or for external relay modules is not permitted, since at least two bus stations are assigned the same bus address.</p> <p>Remedy: Check and correct the configuration for measuring points with digital interface or for external relay modules with the GMA200Config software. If necessary use the GfG service.</p> |
|  | <p>Invalid relay or alarm configuration. An alarm was configured at a measuring point that is not linked to any relay.</p> <p>Remedy: Check and correct the relay or alarm configuration for all measuring points with the GMA200Config software. If necessary use the GfG service.</p> |

4.3.4 Maintenance

Maintenance operation is signalled if the safety function of the GMA22 is reduced or no longer available due to deliberate intervention by an operator or service personnel. In any case, maintenance is indicated by a flashing of the yellow LED "SRV/SQR" and by switching on the maintenance relay. The following causes may be responsible for the maintenance operation:

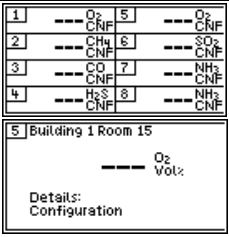
Maintenance on the GMA22

| | |
|---|---|
|  | <p>Configuration change with the GMA200Config software</p> <ul style="list-style-type: none"> • Locking of measuring points or relays • Change of the measuring point or relay configuration • Change of the general GMA configuration • Relay test of internal relays or on external relay modules |
|  | <p>Configuration change via the service menu of the GMA22</p> <ul style="list-style-type: none"> • Change of alarm thresholds of measuring points • Fine adjustment of ZERO and SPAN for analogue measuring points • Changing the BUS settings • Interlocking of at least one measuring point (INH = inhibit) • Interlocking of at least one relay • Relay test of internal relays or on external relay modules |

Maintenance on the transmitter

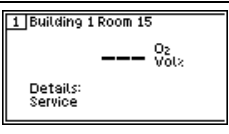
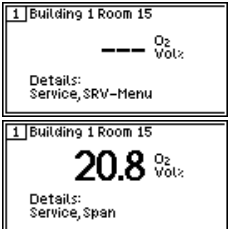
| | |
|---|---|
|  | <p>In a series of transmitters with analogue interface, the current level signals to the GMA22 that maintenance work is being carried out on the transmitter. In this case, no measured value is displayed and, depending on the screen, is shown under the gas type "SRV" or under "Maintenance" detail.</p> |
|  | <p>For transmitters with digital interface (bus), the GMA is signalled that maintenance work is being carried out on the transmitter. Depending on the screen, "SRV" is displayed under the gas type or "Maintenance" is displayed under Details in the individual display in combination with "SRV Menu", "Zero" or "Span". Normally no measured value is displayed here. Only in the individual display is a measured value also displayed during the zero point (Zero) and sensitivity adjustment (Span).</p> |

Depending on the cause that led to the maintenance operation, only part of the safety function of the GMA22 may have been cancelled at that moment. If necessary, the safety function of the GMA22 is still intact for the parts not affected. But only when all causes for the maintenance operation have been eliminated, the yellow SRV/SRQ LED goes out again and the maintenance relay is switched off.

4.3.5 Configuration by parameterization

The configuration of the GMA22 can only be changed to a very limited extent by changing parameters via the service menu on the device itself. For more details, see section 4.5 "Service Menu".

| | | | | | |
|---|-----|------------------|---|-----|-----------------|
| 1 | --- | O ₂ | 5 | --- | O ₂ |
| | --- | CNF | | --- | CNF |
| 2 | --- | CH ₄ | 6 | --- | SO ₂ |
| | --- | CNF | | --- | CNF |
| 3 | --- | CO | 7 | --- | NH ₃ |
| | --- | CNF | | --- | CNF |
| 4 | --- | H ₂ S | 8 | --- | NH ₃ |
| | --- | CNF | | --- | CNF |

However, the GMA22 can be fully configured by means of a PC and the configuration software "GMA200Config" via a USB connection. As soon as the configuration software has established a connection with the GMA22, operation via the service menu is no longer possible. If the configuration of the GMA22 is then changed with the configuration software, this state is shown in the display with "**CNF**" at all measuring points. In this configuration phase, the special status "Maintenance" is simultaneously activated (see section 4.3.4 "Maintenance"). When the configuration is terminated by the configuration software, the GMA22 returns to normal measuring operation.

4.4 Main menu

User guidance in the main menu is provided by the keyboard on the GMA22 controller (see section 4.1 "Keyboard and operation"). The dialogues described below apply to the display language "English".



The main menu is divided into:

- Status GMA
- Status Data logger
- Info GMA
- Info Measuring Points
- Info Relay
- Tests (test LCD display, LED/horn)
- Service menu (password protected, see section 4.5)
- Exit (the main menu)

To return from the main menu to the measured value displays in measuring mode, select the menu item "Exit" and press  the key.

4.4.1 Main menu / "Status GMA"



The "Status GMA" is divided into

- Message
- Fault
- Service Request
- Additional Readouts (supply voltages and temperature)

The numbers in brackets behind Message, Fault and Service Request are the number of single messages on this topic. The "!" behind the number indicates still active messages, faults and maintenance requirements. If there is no "!" behind the number, this is only a stored information, which is no longer active.

In the menu item "Additional Readouts" the GMA supply voltages Upwr(int) and Upwr(ext) are displayed, of which in the case of a GMA with internal power supply both voltages should typically be in the range of 23...24V, and in the case of a GMA without internal power supply these voltages should be in the range of 20...30V. Furthermore, the CPU supply voltage Ucpu is displayed, which should typically be 3.3V or in the range of 3.1...3.5V, and the temperature measured inside the device, which however is always slightly higher than the ambient temperature, depending on the activity of the internal relays, the electronics and possibly the power supply.

4.4.2 Main menu / "Status data logger"



The logging of data can be stopped or restarted in this menu.

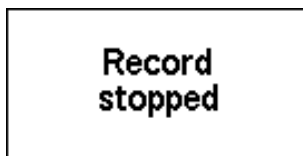

Note: It is essential to stop recording before removing the memory card. If this is not done, data on the memory card may be lost.

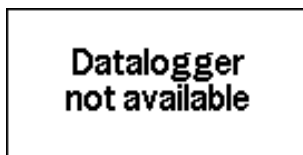

Hint: The data logger is only optionally available. If you wish to use this function, please contact a service or sales representative of the manufacturer.

4.4.3 Main menu / "Info GMA"

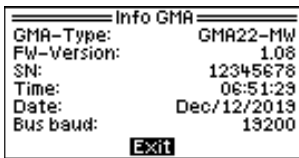

With "Info GMA" the following information can be displayed:

- GMA-Type (device type)
- FW-Version (version of the firmware)
- SN (serial number of the GMA22)
- Time (current time of the clock module of the GMA22)
- Date (current date of the clock module of the GMA22)
- Bus baud (setting the bus baud rate)

4.4.4 Main menu / "Info Measuring Points"

In this menu item the parameterization of the analogue and also the digital transmitters can be checked. A change is not possible.

A few examples are given below:

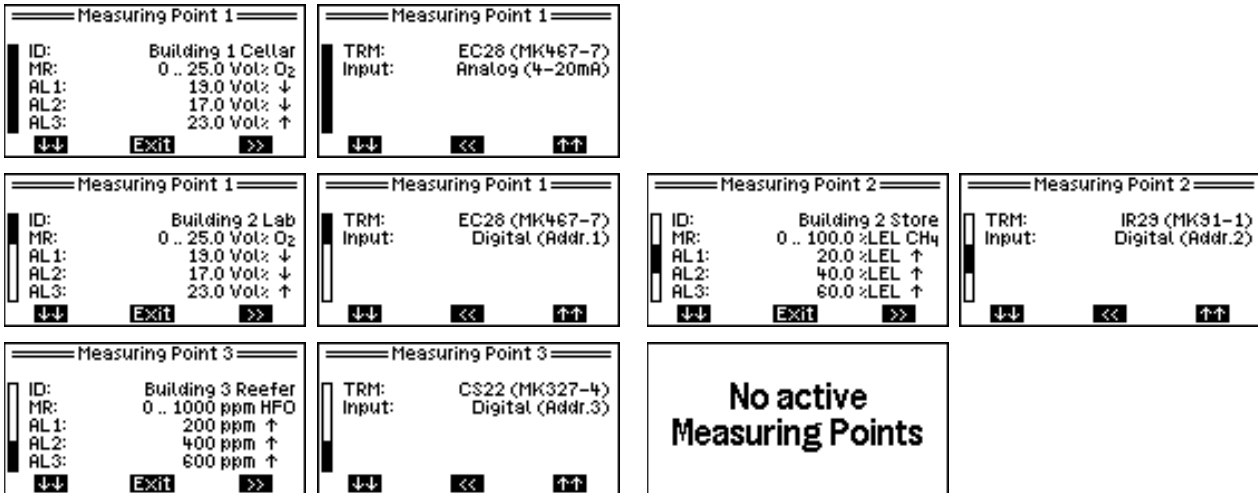

Note: Minor adjustments are possible, as shown in section 4.5.3 "Service menu / "Measuring Points More complex changes, such as adding or removing measurement points, are only possible by using the GMA200Config configuration software.

4.4.5 Main menu / "Info Relay"

With "Internal Relay" some information about the individual relays can be called up.

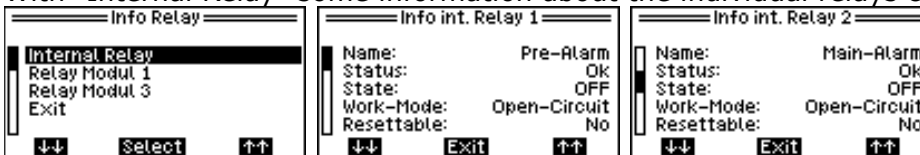

With "Relay Module X" some information about the external relay module and its individual relays can be called up.



4.4.6 Main menu / "Tests"

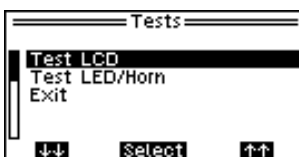

In the submenu "Tests" a test of the LCD display as well as all LEDs and the internal horn can be performed.

4.4.6.1 Tests / "Test LCD"

After switching on the device, a display test is automatically started. This test can be additionally triggered here. If defects are detected, the device must be replaced.



4.4.6.2 Tests / "Test LED/Horn"

After switching on the device, an LED/horn test is automatically started. This test can be additionally triggered here. If malfunctions are detected, the device must be replaced.



4.4.7 Main menu / "Service Menu"



Settings can be displayed and changed in the service menu. In the following section, the scope of functions is described in detail.

4.5 Service Menu

Hint: Access to the "Service Menu" is blocked when the GMA22 is connected to the GMA200Config software. The connection must be terminated first.



Because of this special functionality, access to this menu is password protected. The password is set to "0000" by default on delivery. This password can be changed in the service menu.

Hint: Likewise, the GMA200Config software cannot be connected to the GMA22 while at the same time the "Service Menu" is activated on the GMA22.



The "Service Menu" is divided into five submenus:

- System Settings
- Datalogger
- Measuring Points
- Relay
- Exit

The submenus are described in the following sections.

4.5.1 Service Menu / "System Settings"

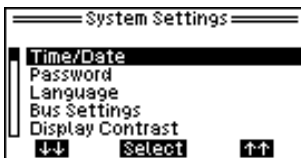

Options in the "System Settings" menu:

- Time/Date
- Password
- Language
- Bus Settings
- Display Contrast
- Horn Volume

4.5.1.1 System Settings / "Time/Date"



The following can be set or changed here:

- Time
- Date
- Format (Date format either DD.MM.YYYY or YYYY-MM-DD)

4.5.1.2 System Settings / "Password"

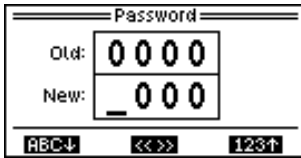

The password for accessing the "Service Menu" can be changed here. The new four-digit code can consist of any alphanumeric characters and some special characters.

Note: If the password is no longer known, it can only be read out and also changed using the GMA200Config configuration software.

4.5.1.3 System Settings / "Language"



Here you can switch between the display languages German and English. (Default = German).

4.5.1.4 System Settings / "Bus Settings"

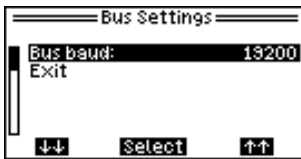

Here the bus baud rate can be changed.

The following settings are possible:

9600/19200/38400/57600/115200/230400 bps (**default=19200**)

4.5.1.5 System settings / "Display Contrast"

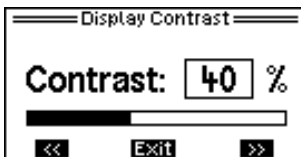

The contrast of the LCD display can be adjusted here between 0 and 100% in 5% steps to suit local conditions. (default = 40%).

4.5.1.6 System Settings / "Horn Volume"

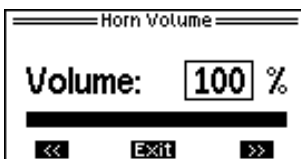

The volume of the internal horn can be adjusted here between 0 and 100% in 5% steps. (default = 50%).

4.5.2 Service Menu / "Data Logger"

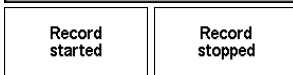

With "SRV-REC" the data recording for service purposes on the microSD card can be started or stopped for a maximum of 8 hours. This data recording for service purposes works even if the GMA has no data logger. (file name: *S.txt)

With "LOG-REC" the data recording of the normal data logger can be switched on or off.

4.5.3 Service menu / "Measuring Points"

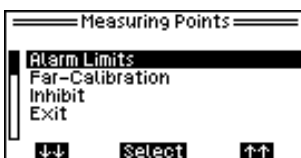

The submenu "Measuring Points" is further subdivided into three submenus: 1.Alarm Limits, 2.Remote Calibration and 3.Inhibit

4.5.3.1 Measuring Points / "Alarm Limits"

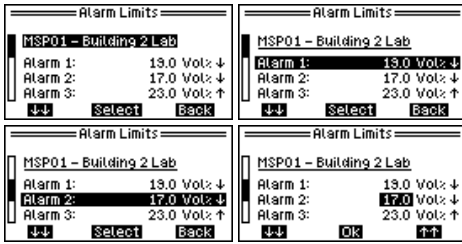

With "Alarm Limits", the limit values for Alarm 1, Alarm 2 and Alarm 3 can be altered within the measuring range after selecting the measuring point. If the alarm threshold is set to 0.0 (zero), the alarm is switched off.

The alarm direction is marked with an arrow behind the gas unit (overrange or underrange).

4.5.3.2 Measuring Points / "Fine Calibration"

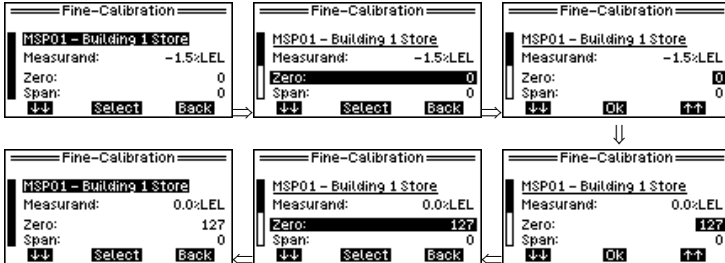

The measured value of the GMA may show small deviations compared to the current signal of a transmitter with analogue interface. With "Fine Calibration" these small deviations can be compensated.

Under "Zero" the lower range value and under "Span" the upper range value can be adjusted by $\pm 1.27\%$ of the measuring range respectively.

The number which can be altered at "Zero" in the range of -127...0...127 is an additive correction value which changes the measuring value by -1.27%...0%...+1.27% of the measuring range. The number which can be altered at "Span" in the range from -127...0...127 is a correction value which alters the normal characteristic curve slope by -1.27%...0%...+1.27% of the measuring range, i.e. a measured value at the end of the measuring range would be altered by this value.

4.5.3.3 Measuring Points / "Inhibit"



Measuring points can be locked for maintenance purposes (INH=inhibit).

Service work can then be carried out at the measuring points without triggering a gas alarm.

Note: If a measuring point is locked, the special condition Maintenance is assumed. This means that the maintenance relay remains switched on even during measuring operation. In measuring mode, the yellow LED "SRV/SRQ" flashes and the collective screen displays "----" instead of the measured value and "SRV" instead of the gas unit for the locked measuring point. In the individual display of the locked measuring point, "SRV-INH" is then displayed under Details. The condition is not limited in time. Even if the power supply is interrupted and the GMA is then put back into operation, the condition is maintained.

4.5.4 Service Menu / "Relay"



The menu element "Relay" offers three further options:

- Test
- Inhibit
- Time Control Start

4.5.4.1 Relay / "Test"

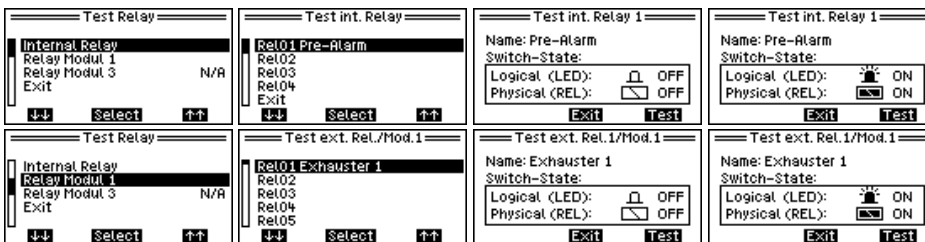

Via relay "Test" the switching of internal relays of the GMA22 and of relays on external relay modules can be tested.

4.5.4.2 Relay / "Inhibit"

Individual or multiple relays can be inhibited for maintenance purposes (INH=inhibit).

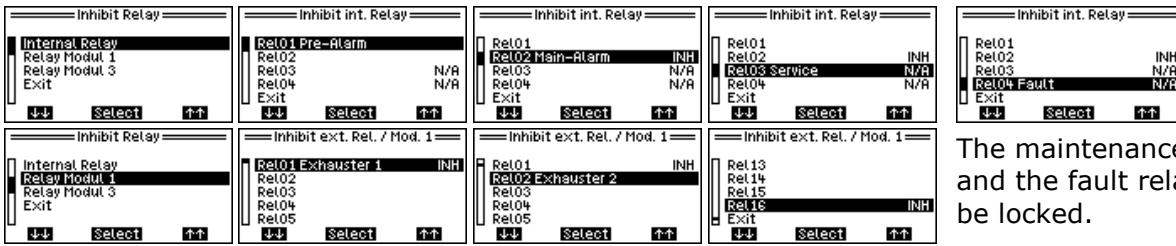

The maintenance relay and the fault relay cannot be locked.

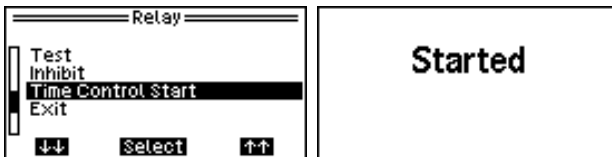

Note: If a relay is latched, the special state maintenance is assumed. This means that the maintenance relay is switched on. In measuring mode, the yellow LED "SRV/SRQ" then lights up continuously. In the main menu, under Status GMA in Messages, it is indicated that "At least one relay is locked" since the date. The status is not time-limited. Even if the power supply is interrupted and the GMA is then put back into operation, the status is retained.

4.5.4.3 Relay / "Start time control"



Optionally, the GMA22 offers the possibility to switch relays time-controlled. If such a time control has been configured and "key (service menu)" has been set as start condition in the GMA200Config software, the time control can be started here.

4.5.5 Exit Service Menu

To return from the service menu to the main menu, the menu item "Exit" must be selected   with the keys and confirmed  with. To change from the main menu to the measured value displays in measuring mode, the menu item "Exit" must be selected and confirmed again. If settings have been changed in the service menu, the following prompt appears when exiting the service menu:



Hint:

Safety-relevant modifications may only be carried out by authorized and competent personnel.

To verify that the setting changes have been applied as desired after saving, it can be checked by switching back to the service menu. Especially after changing safety-relevant settings, such as the alarm thresholds, it has to be done in this way.

5 Annex

5.1 Cleaning and care

External soiling of the device housing can be removed with a cloth moistened with water when the device is disconnected from the mains voltage. Do not use solvents or cleaning agents!

5.2 Service and maintenance

Maintenance and servicing includes regular visual inspections, function checks and system checks as well as the repair of the gas detection system. (see DIN EN 60079-29-2 Section 11, DIN EN 45544-4 Section 8 as well as the "DGUV Information 213-056 (Leaflet T 021 Section 9)" and the "DGUV Information 213-057 (Leaflet T 023 Section 9)" which are valid in Germany.

5.2.1 Visual inspection

The visual inspection should be carried out regularly, with a maximum interval of one month, and should include the following activities:

- Checking the operation display and status messages, e.g. operation display "On", alarm and fault displays "Off"
- Check for mechanical damage and external contamination

5.2.2 Functional check

The function check can be carried out at intervals that depend on the gas hazard to be monitored. For gas detection devices for toxic gases/vapours and oxygen as well as for gas detection devices for explosion protection, the inspection periods are 4 months in accordance with the requirements of regulations T°021 and T°023 of the BG°RCI (German Employers' Liability Insurance Association).

It comprises the following activities:

- Visual inspection according to paragraph 5.2.1 "Visual inspection".
- Control and evaluation of measured value displays
- Triggering the alarm thresholds
- Triggering of test functions for display elements as well as optical and acoustic signaling devices without triggering switching functions
- Control of stored messages, faults and maintenance requirements

5.2.3 System control (Proof Test)

The system check must be carried out at regular intervals. The period may not exceed 1 year. It comprises the following activities:

- Function check according to section 5.2.2 "Functional check".
- Control of all safety functions including the triggering of switching functions.
- Control of the parameterization by target/actual comparison
- Inspection of the reporting and registration facilities

5.2.4 Repair

The repair includes all repair and replacement work. They may only be carried out by the manufacturer and by persons authorized by the manufacturer GfG Gesellschaft für Gerätebau mbH. Only original spare parts and original assemblies tested and approved by the manufacturer may be used.

If the GMA internal fuses for the transmitter supply have to be changed, the housing cover must be removed first. The pluggable fuse F1 is located at the top right.

Hint: When replacing the fuse, care must be taken to ensure ESD protection of the components on the circuit boards.



5.3 Spare parts and accessories

| | Designation | | Item no. |
|----|--|---------------|----------|
| 1. | microSD card 2GB | | 2200202 |
| 2. | Screws for GMA22 housing cover | VPE=15 pieces | 2200330 |
| 3. | Seal for GMA22 Cable gland | VPE=10 pieces | 2200331 |
| 4. | Spare fuse T315mA (F1 for TRM supply from int. NT) | VPE= 5 pieces | 2200332 |
| 5. | Spare fuse T630mA (F1 for TRM supply from ext. NT) | VPE= 5 pieces | 2200333 |

5.4 Notes on the environmentally friendly disposal of used parts



According to GfG's general terms and conditions, the customer assumes responsibility for the environmentally safe disposal of the device or any device components (such as replaced sensors). In Germany, this is regulated by §§11, 12 ElektroG. On request, GfG in Dortmund can also handle the proper disposal.

5.5 Technical data

| | | |
|--|--|---|
| Type designation: | GMA22-MW, GMA22-MS | |
| Display & control elements | 2,2" graphic display, 3 buttons and a buzzer max.100dB(A) adjustable 4 status LEDs for alarms and operating states | |
| Environmental conditions Mounting: Storage: Operating conditions GMA22-MW: Operating conditions GMA22-MS: | only indoors up to an altitude of 2000m above sea level -25...+60°C 5...95%rh (recommended 0...+30°C 40...60%rh) -20...+50°C 5...95%rh (without internal PSU) -20...+45°C 5...95%rh (with internal PSU and max. 150mA load at Uout) -20...+40°C 5...95%rh (with internal PSU and max. 250mA load at Uout) -20...+55°C 5...95%rh (without internal PSU) -20...+50°C 5...95%rH (with internal PSU and max.150mA load at Uout) -20...+45°C 5...95%r.H. (with internal PSU and max. 250mA load at Uout) | |
| Power supply (PSU) Operating voltage Ue: Power consumption: Fuses: | GMA22 with internal PSU 100-240V AC mains voltage 50-60Hz max.25VA (with transmitters) max. 6VA (without transmitter) F1: T315mA changeable (for TRM) F2: 250mA not changeable (for GMA internal) | GMA22 without internal PSU 24V DC (20-30V DC) through stabilized SELV or PELV power supply max. 20W (with transmitter) max. 5W (without transmitter) F1: T630mA changeable (for TRM) |
| Transmitter connections Supply output Uout: Analog signal input I _{IN} : Digital signals RS485 bus: | 24V DC ±5% of internal power supply max .300mA 4-20mA or 0.2-1mA (4-20mA with ACDC capability) Tolerance (s.#2): ±0.3%MR@4-20mA or ±1.2%MR@0.2-1mA (MR=measuring range) (load approx.50..100Ω, I _{max} =70mA permanent / 500mA temporary) RS485; Half-Duplex; max. 38400 Baud | 24V DC (20-30V DC) from external power supply max.600mA |
| Measurement processing Update time: Setting times for RS485 : at 4...20mA: at 0.2...1mA: Standby delay: | 1s Rise time t ₅₀ < 2s or t ₉₀ < 2 sec Rise time t ₅₀ < 2s or t ₉₀ < 4sec Rise time t ₅₀ < 6s or t ₉₀ < 10sec (extended by setting times of the gas measuring transmitters) <40s (can be extended by running-in times of gas measuring transmitters) | Decay time t ₅₀ < 2s or t ₁₀ < 2sec Decay time t ₅₀ < 2s or t ₁₀ < 4sec Decay time t ₅₀ < 6s or t ₁₀ < 10sec |
| RS485 output RS485 bus: | RS485; half-duplex; max. 38400 Baud (only for GMA200 relay modules) | |
| Relay outputs Contacts of the GMA22-MS : contacts of the GMA22-MW: Insulation spacing GMA22-MS : Insulation spacing GMA22-MW: Contact load capacity: Minimum switching current: Minimum switching voltage: | 4 relays NO 4 relays SPDT (GMA22-MW without internal PSU) 3 relays SPDT, 1 relay NO (GMA22-MW with internal PSU) Double insulation between adjacent relays Basic insulation between adjacent relays 3A/250V AC or 3A/30V DC 10mA 5V | |
| Data logger (optional) | max. 2GB microSD card with FAT formatting (FAT16) | |
| USB connection | Mini USB socket for device configuration with PC | |
| Housing Protection class: material: Weight: measurements: | IP64 according to IEC 60529; IK08 according to IEC 62262 Plastic approx. 275g 97 x 140 x 50mm (W x H x D) | |
| Cable junction Cable: Cable glands: Terminal blocks: | 3-wire ≥0,75mm ² LiYY, NYM (for GMA supply) 2-4 wires 0.5...1.0...(1.5)mm ² LiYY, LiYCY, Y(St)Y (for transmitters) 5 pieces M16x1,5 (for cable diameter 4,5-10mm) 0.5...1.0mm ² cross section (1.5mm ² for solid conductor) | |
| Approvals/Tests Electromagnetic compatibility: Electrical safety: | EN 50270:2015 (interference emission: type class I, interference immunity: type class II) EN 61010-1:2010 (pollution degree 2, overvoltage category II for mains supply) (pollution degree 2, overvoltage category III for relay contacts) | |
| Service life | 20 years | |

Note #2: This is only the measurement tolerance of the GMA. The transmitters have additional tolerances.

| | |
|--|--|
| GfG Gesellschaft für Gerätebau mbH Klönnestraße 99; D-44143 Dortmund Phone: +49 (0)231-56400-0 Internet: www.gasmessung.de Fax: +49 (0)231-56400-895 E-mail: info@gfg-mbh.com Firmware version 1.07 238-000.30_BA_GMA22-M.doc Status: December 07, 2022 |  |
|--|--|

5.6 EU Declaration of Conformity

EU Declaration of Conformity

GMA22-MW
GMA22-MS

Edited: 12.11.2019 Amended:

GfG Gesellschaft für Gerätebau mbH

Klönnestrasse 99
D-44143 Dortmund
Tel: +49 (231) 56400-0
Fax: +49 (231) 516313
E-Mail: info@gfg-mbh.com
www.gfg.biz



GfG Gesellschaft für Gerätebau mbH develops, produces and sells gas sensors and gas warning devices, which are subject to a **quality management system** as per DIN EN ISO 9001. Subject to supervision by means of a **quality system**, surveilled by the notified body, DEKRA Testing and Certification GmbH, is the production of electrical apparatus of instrumentation Group I and II, categories M1, M2, 1G and 2G for gas sensors, gas detectors, gas warning systems in ignition protection classes explosion- proof encasing, increased safety, encapsulation and intrinsic safety, as well as their measuring function.

The Gas Monitor **GMA22-M** complies with council directive **2014/30/EU** for electromagnetic compatibility, with directive **2014/35/EU** for electrical safety and with directive **2011/65/EU** (RoHS) on the restriction of the use of certain hazardous substances in electrical and electronic equipment.

The directive 2014/30/EU is complied considering the following standard:

- Electrical apparatus for the detection and measurement of combustible gases, toxic gases and oxygen EN 50270 : 2015
- Radio shielding: Type class 1
- Interference resistance: Type class 2

The EMC test laboratory AMTEK CTS Europe GmbH at Kamen has tested and certified the electromagnetic compatibility.

The directive 2014/35/EU is complied considering the following standard:

- Safety requirements for electrical equipment for measurement, control and laboratory use. General requirements. EN 61010-1 :2010

The directive 2011/65/EU is complied considering the following standard:

- Technical documentation for the assessment of electrical and electronic products with respect to the restriction of hazardous substances EN 50581 : 2012

Dortmund, 15 November 2019

B. Siebrecht
QMB

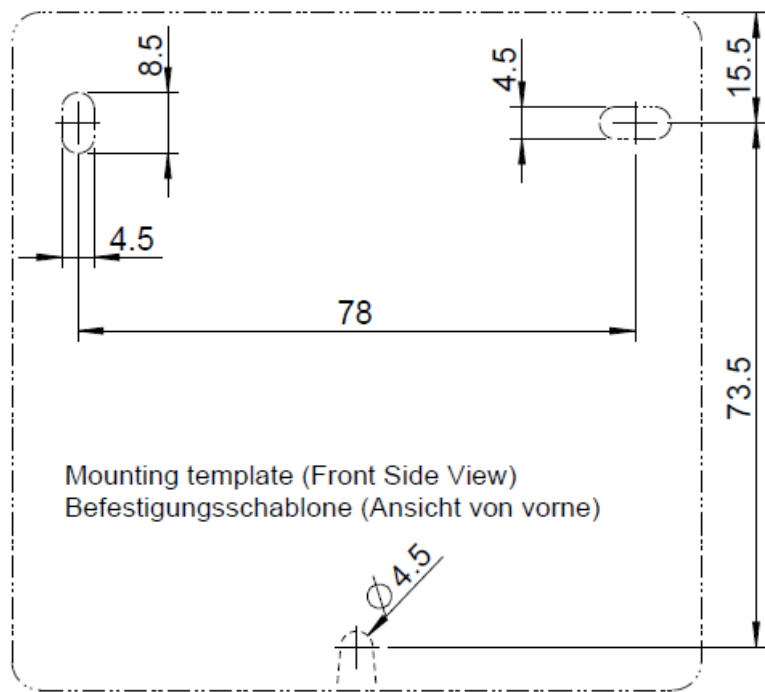
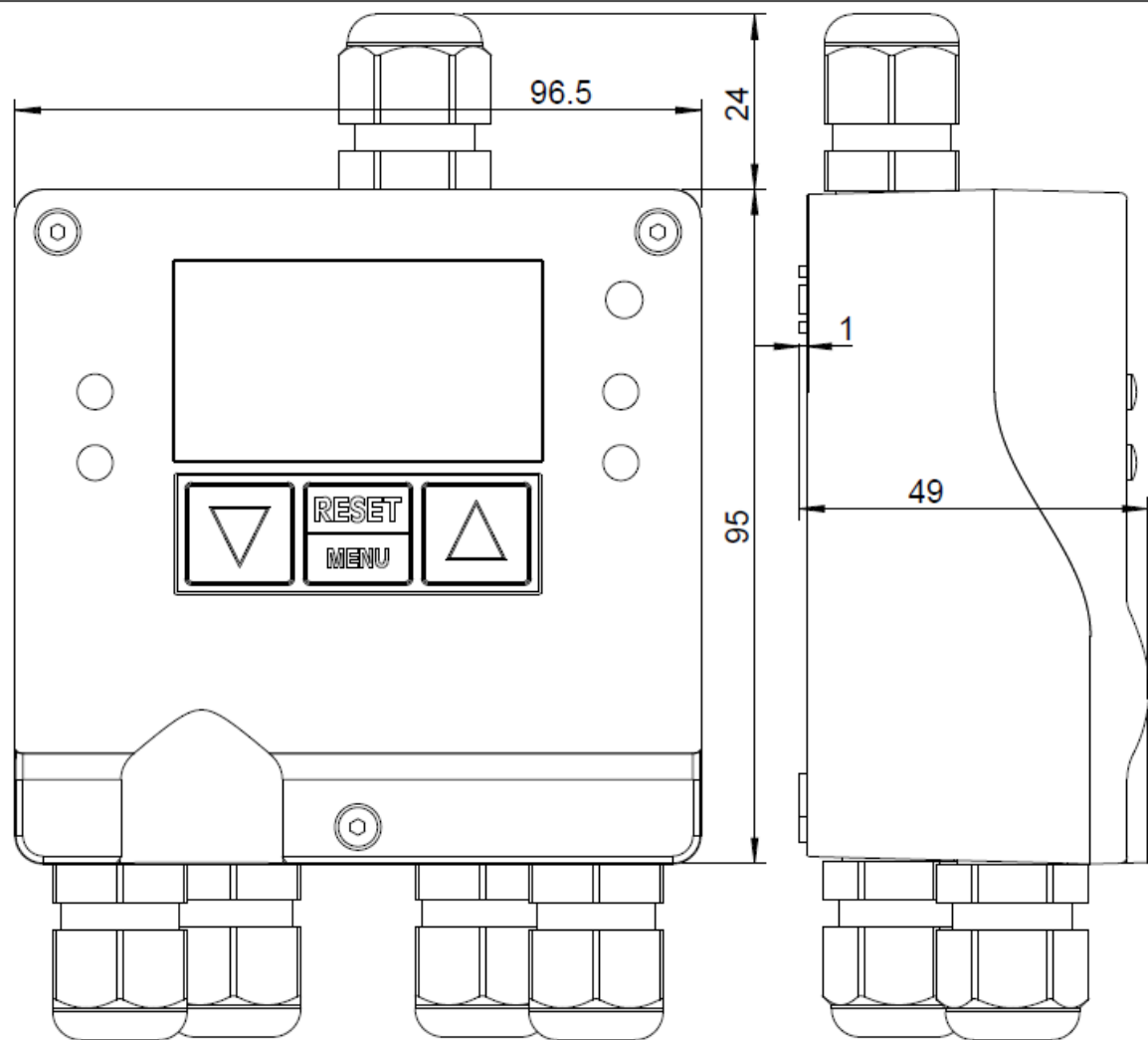

| General Tolerance ISO 2768 - m | | Material: - | | | | | Scale: 1:1 |
|--|---------|-------------|------|------------|-----------|--------------|--|
| Rev. | Changes | Date | Name | Date | Name | Verified | Tm: GMA22 Package dimensions and mounting template |
| | | | | 2019-08-12 | Leonhardt | Böttger | |
| Adhere to protection note ISO 16016 Schutzvermerk ISO 16016 beachten | | | | | | | Document-No.: 238-005.10 |
| GfG Gesellschaft für Gerätebau mbH Klönnestr.99, D - 44143 Dortmund | | | | | | | |
| Replaces: | | | | | | Replaced by: | |